

Analytical Application Sets

Continuous emission monitoring

Set CEM 1

Overview



The Set CEM 1 is a standardized system specially for monitoring the emission components in flue gases.

Benefits

Standardized complete system

- Highly exact and reliable monitoring of emission components in flue gases. System-specific certificate according to DIN EN ISO 14956 and QAL 1, according to EN 14181 (2004).
- Modular complete package with gas sampling system, sample gas preparation system and gas analyzers from one source
- Simple and fast to configure
- Tried and tested, harmonized and reliable set
- Low purchase price and economic operation

Proven, suitability-tested technologies

- Continuous determination of up to eight measured components
- In-situ measurements without sampling and preparation, using LDS 6 laser diode spectrometer
- Use of ULTRAMAT 23 with cleanable cells and automatic calibration with ambient air as well as optional electrochemical oxygen measurement

Optional:

- Paramagnetic oxygen measurement with OXYMAT 6

Simple operation

- Intuitive operation
- Configuration on large displays using plain text, in several languages

Simple maintenance

- Maintenance-friendly cabinet design with hinged frame and uniform design
- Digital display of maintenance requests on LOGO modules

Application

The monitoring of emission components in flue gases is one of the most important topics for continuous gas analysis. This is a result of legislation for monitoring emissions, e.g. for large combustion plants, and also due to the requirements of companies operating process plants who can draw conclusions on the process efficiency from the gas analyses, e.g. with boiler control, DENOX and DESOX plants.

The market requires a reliable complete system which is specially designed for the application. The Set CEM 1 (Continuous Emission Monitoring) offered by Siemens is a system which reliably covers all requirements associated with sampling, sample preparation, and gas analysis.

It is possible to determine the concentrations of the gaseous components CO, CO₂, NO, NO_x, SO₂, O₂, C_{total}, HCl, HF, NH₃ and H₂O.

The ULTRAMAT 23 and OXYMAT 6 are used for the extractive, continuous gas analysis.

The standardized Set CEM 1 provides great clarity and simple configuration facilities. Different versions mean that it is possible to appropriately adapt the system to the requirements. Standardization also means that not all imaginable versions can be included, and that it may not be possible to implement special requirements such as armored cables, varying gas compositions, customer-specific documentation or specific conductor labeling without an extra charge.

Design

Starting with a mounting frame with sample preparation system, it is possible to add additional units as options. These include:

- Sampling probe with weather protection hood
- Heated sample gas line (for details see catalog PA11)
- Analyzers
- Air-conditioning unit
- NO₂/NO converter
- Sample preparation extension for an additional ULTRAMAT 23 analyzer
- Single and dual (electrically isolated, not electrically isolated) analog signal processing
- Power supply modules (115 V, 230 V, 400 V)
- Outer panels with steel-plate door or with window
- Single-pole and double-pole fusing
- Condensation bottle
- Coalescence filter

Sampling probe

The standard probe is fitted with a DIN flange DN 65, PN 6. The probe is provided with a regulated heater, and has a power consumption of 400 VA. It is supplied with a weather protection hood and 2 µm filter. The maximum dust concentration at the sampling point should not exceed 2 g/m³. The sampling pipe is 1 000 mm long, is made of stainless steel, and has dimensions of 20 x 1.5 mm. The sample gas temperature must not exceed 600 °C.

It is also possible to purchase the Set CEM 1 without sample probe.

Heated sample gas line

The temperature of the heated line is regulated at 200 °C by a temperature controller. The power consumption is 100 VA per meter. The internal core is made of PTFE 4/6. The heated line can be up to 35 m in length. Lengths greater than 35 m can be provided upon special request. If desired, the system can also be supplied without a heated sample gas line.

Mounting frame

The basis of each CEM 1 set is the mounting frame with hinged frame (40 HU) for installation of up to five 19" rack units. The mounting frame includes a standardized sample preparation system designed for an ULTRAMAT 23.

The sample preparation system includes a 3/2-way solenoid valve, 3-way switchover ball valve, regulating valve, corrosion-resistant sample gas pump (power consumption 60 VA), condensation trap, room air suction filter with filter element, LOGO for digital display of individual signals in the cabinet, 24 V DC power supply unit (power consumption 70 VA). Also included are a sample gas cooler (power consumption 200 VA) with integral heat exchanger, hose pump, moisture sensor with flow cell and Teflon filter. Teflon tubes connect the components.

The external dimensions without plinth are 2 000 x 800 x 800 mm (H x W x D). A cabinet depth of 600 mm is also optionally available (not suitable for LDS 6). Hoses and cables can be connected from the left or right. A distance of 500 mm must be provided on the left or right at the installation site for introduction of the hoses and cables.

In addition to the sheet-steel mounting frames for indoor installation, an FRP version is also available for outdoor use. The FRP cabinet is always provided complete with side panels and plinth. The external dimensions are 2 080 x 800 x 600 mm (H x W x D). The GRP cabinet cannot be combined with the LDS 6.

Preparation of sample preparation system for second ULTRAMAT 23

The standard system with sample preparation system and electronics is prepared for one ULTRAMAT 23. If a second ULTRAMAT 23 is to be fitted, this option must be selected so that the sample preparation system and electronics are extended accordingly.

Additional filter

In addition to the fine filter and moisture filter which are always present, a coalescence filter can be optionally fitted in the sample preparation system.

Side panels with doors

Optional outer panels can be selected for the sheet-steel mounting frames. This possibility allows use of the CEM 1 set in analysis cabinets as a rack design on one hand, or on the other as a cabinet design in halls requiring degree of protection IP54. Either a sheet-steel door without window or a glass door can be selected.

Base

Plinths with a height of 100 and 200 mm are additionally available.

Cabinet cooling and ventilation

Optionally available are a fan with outlet filter, an air-conditioning unit for indoor installation, and an air-conditioning unit for outdoor installation. The system can be ordered without a fan or air-conditioning unit if the side panels and the door with window are omitted.

The fan with outlet filter has a power consumption of 60 VA, and is fitted in the cabinet wall. The delivery also includes a thermostat with a power consumption of 25 VA.

The air-conditioning unit has a cooling power of 820 VA.

Frost protection heater

The power consumption of the optional cabinet heater is 500 VA. The delivery includes a thermostat with a power consumption of 25 VA for controlling the frost protection heater.

Fusing of the analog signals

In addition to single-pole fusing of the electronic consumers, it is possible to provide double-pole fusing.

The double-pole fuse is mainly required in Benelux countries.

Removal of condensation

A 19 liter condensation bottle can be provided as an option. It is also possible to order the system without a condensation bottle if the condensation can be removed on-site.

NO₂/NO converter

The mounting frame and cabinets can be optionally extended by a 19" rack unit with NO₂/NO converter with carbon cartridge. The power consumption is 520 VA. The flow rate is 90 l/h. An NO₂/NO converter is required if the share of NO₂ in the total NO_x is greater than 5 % and/or if total NO_x is to be always determined.

Power supply

The system can be designed either for 115 V AC, 230 V AC or 400 V AC (-15 %, +10 %) with 50 or 60 Hz.

Three phases, neutral and ground must be provided by the customer at 400 V AC.

Analog signal processing

As standard, the analog signals are simply connected to isolating terminals. As an option, the analog signals can be processed twice without electrical isolation by a diode module, or twice with electrical isolation.

Analyzers

The standardized set is prepared for an ULTRAMAT 23. The system can be supplemented by a second ULTRAMAT 23, OXYMAT 6 and/or LDS 6. Various measured components and measuring ranges can be selected. Other combinations of measured components and measuring ranges are available on request, but you must check that the desired certificates and approvals are available. The analyzers, measured components and measuring ranges used are described briefly below.

Details on the analyzers, alternative components and ranges can be found under the topics "Continuous gas analyzers, extractive" and "Continuous gas analyzers, in-situ".

ULTRAMAT 23: CO, NO

For measuring two infrared components.

Component	Smallest tested measuring range	Switchable to
CO	0 ... 150 mg/Nm ³	0 ... 750 mg/Nm ³
NO	0 ... 100 mg/Nm ³	0 ... 500 mg/Nm ³

One or two measuring ranges can be freely set within the limits. The ULTRAMAT 23 carries out automatic self-calibration with ambient air. The power consumption is 60 VA.

Analytical Application Sets

Continuous emission monitoring

Set CEM 1

ULTRAMAT 23: CO, NO, SO₂

For measuring three infrared components.

Component	Smallest tested measuring range	Switchable to
CO	0 ... 250 mg/Nm ³	0 ... 1 250 mg/Nm ³
NO	0 ... 400 mg/Nm ³	0 ... 2 000 mg/Nm ³
SO ₂	0 ... 400 mg/Nm ³	0 ... 2 000 mg/Nm ³

One or two measuring ranges can be freely set within the limits. The ULTRAMAT 23 carries out automatic self-calibration with ambient air. The power consumption is 60 VA.

ULTRAMAT 23: CO, NO, CO₂

For measuring three infrared components.

Component	Smallest tested measuring range	Switchable to
CO	0 ... 250 mg/Nm ³	0 ... 1 250 mg/Nm ³
NO	0 ... 400 mg/Nm ³	0 ... 2 000 mg/Nm ³
CO ₂	0 ... 5 %	0 ... 25 %

One or two measuring ranges can be freely set within the limits. The ULTRAMAT 23 carries out automatic self-calibration with ambient air. The power consumption is 60 VA.

The component CO₂ has not been type approved by the TÜV.

ULTRAMAT 23: CO₂

For measuring one infrared component.

Component	Smallest measuring range	Largest measuring range
CO ₂	0 ... 5 %	0 ... 25 %

One or two limits can be freely set within the limits. The ULTRAMAT 23 carries out automatic self-calibration with ambient air. The power consumption is 60 VA.

The component CO₂ has not been type approved by the TÜV.

The ULTRAMAT 23 analyzers can be optionally equipped with an electrochemical oxygen sensor.

O₂: Tested measuring ranges 0 to 10/25 %

OXYMAT 6: O₂

For paramagnetic measurement of oxygen. Instead of ULTRAMAT 23 with electrochemical cell.

O₂: Tested measuring ranges 0 to 10/0 to 25 %

Sample chamber without flow-type compensation branch, made of stainless steel 1.4571.

LDS 6: HCl

Component	Smallest tested measuring range
HCl	0 ... 15 mg/Nm ³

Application for channel 1: Emission monitoring

The power consumption is 50 VA. Suitable for connection of non-Ex sensors, including non-Ex-protected sensor electronics.

The delivery includes a pair of sensors for instrument air or N₂ on the process side. The pair of sensors is designed for a moderate flow rate of 0 to 120 l/min. The 400 mm long purging tubes are made of stainless steel. The process connection is DN 65, PN 6. The power consumption is 2 VA.

Limitation:

Applies to measurement paths > 2 000 mm, applies to gases with a methane content < 15 mg/m³. Necessary gas temperature between 120 and 210 °C.

LDS 6: HCl / H₂O

Component	Smallest tested measuring range
HCl	0 ... 15 mg/Nm ³
H ₂ O	0 ... 30 %

Application for channel 1: Emission monitoring

The power consumption is 50 VA. Suitable for connection of non-Ex sensors, including non-Ex-protected sensor electronics.

The delivery includes a pair of sensors for instrument air or N₂ on the process side. The pair of sensors is designed for a moderate flow rate of 0 to 120 l/min. The 400 mm long purging tubes are made of stainless steel. The process connection is DN 65, PN 6. The power consumption is 2 VA.

Limitation:

Applies to measurement paths > 2 000 mm, applies to gases with a methane content < 15 mg/m³. Necessary gas temperature between 120 and 210 °C.

LDS 6: HF

HF: Smallest possible measuring range depends on the gas composition.

Application for channel 1: Emission monitoring

The power consumption is 50 VA. Suitable for connection of non-Ex sensors, including non-Ex-protected sensor electronics.

The delivery includes a pair of sensors for instrument air or N₂ on the process side. The pair of sensors is designed for a moderate flow rate of 0 to 120 l/min. The 400 mm long purging tubes are made of stainless steel. The process connection is DN 65, PN 6. The power consumption is 2 VA. The HF measurement has not been type approved by the TÜV.

Limitation:

Component has not been type approved by TÜV. Necessary gas temperature between 0 and 150 °C.

LDS 6: HF/H₂O

HF: Smallest possible measuring range depends on the gas composition.

H₂O: Smallest tested measuring range 0 to 30 %

Application for channel 1: Emission monitoring

The power consumption is 50 VA. Suitable for connection of non-Ex sensors, including non-Ex-protected sensor electronics.

The delivery includes a pair of sensors for instrument air or N₂ on the process side. The pair of sensors is designed for a moderate flow rate of 0 to 120 l/min. The 400 mm long purging tubes are made of stainless steel. The process connection is DN 65, PN 6. The power consumption is 2 VA. The HF measurement has not been type approved by the TÜV.

Limitation:

Component has not been type approved by TÜV. Necessary gas temperature between 0 and 150 °C.

LDS 6: NH₃

Component	Smallest tested measuring range
NH ₃	0 ... 20 mg/Nm ³

Application for channel 1: Emission monitoring

The power consumption is 50 VA. Suitable for connection of non-Ex sensors, including non-Ex-protected sensor electronics.

The delivery includes a pair of sensors for instrument air or N₂ on the process side. The pair of sensors is designed for a moderate flow rate of 0 to 120 l/min. The 400 mm long purging tubes are made of stainless steel. The process connection is DN 65, PN 6. The power consumption is 2 VA.

Limitation:

Applies to measurement paths > 1 250 mm. Necessary gas temperature between 0 and 150 °C.

LDS 6: NH₃/H₂O

Component	Smallest tested measuring range
NH ₃	0 ... 20 mg/Nm ³
H ₂ O	0 ... 15 %

Application for channel 1: Emission monitoring

The power consumption is 50 VA. Suitable for connection of non-Ex sensors, including non-Ex-protected sensor electronics.

The delivery includes a pair of sensors for instrument air or N₂ on the process side. The pair of sensors is designed for a moderate flow rate of 0 to 120 l/min. The 400 mm long purging tubes are made of stainless steel. The process connection is DN 65, PN 6. The power consumption is 2 VA.

Limitation:

Applies to measurement paths > 1 250 mm. Necessary gas temperature between 0 and 150 °C.

Hybrid cable

A hybrid cable is required to connect a central unit to one pair of sensors. Versions for 5, 10, 25, 40 and 50 m are available. Cable lengths cannot be combined. Lengths greater than 50 m can be ordered on request.

Sensor cable

A sensor cable is required to connect one pair of sensors. Versions for 5, 10 and 25 m are available. Cable lengths cannot be combined. Lengths greater than 25 m can be ordered on request.

Electrical preparation for dust measurement

Electrical preparation for connection of an external dust measurement to the system (contains a switch amplifier).

Electrical preparation for flow measurement

Electrical preparation for connection of an external flow measurement to the system (contains a switch amplifier).

Electrical preparation for pressure measurement

Electrical preparation for connection of an external pressure measurement to the system (contains a switch amplifier).

Electrical preparation for temperature measurement

Electrical preparation for connection of an external temperature measurement to the system (contains a switch amplifier).

Electrical preparation for emission data memory on rail module

On request.

Electrical preparation for emission data memory in 19" rack unit

On request.

Additional LOGO for four or more 19" rack units

Sets with more than three 19" rack units integrated require a LOGO extension module. The delivery also includes connection and programming.

Core end labeling

It is optionally possible to order core end labeling according to the Siemens standard (VDE 0100 Part 200).

Documentation

The Siemens standard documentation is available in German or English.

The documentation includes gas path diagram, circuit diagram, terminal diagram, installation diagram, consumable materials list, signal list, cable list, and parts list. Also included are technical data sheets and Operating Instructions for the components and devices used. The documentation language for parts provided by other suppliers may deviate. Plant description, LOGO program and test certificates are also included in the documentation.

The documentation contains no customer-specific/project-specific drawings, and consists of two folders and one CD per set.

Analytical Application Sets

Continuous emission monitoring

Set CEM 1

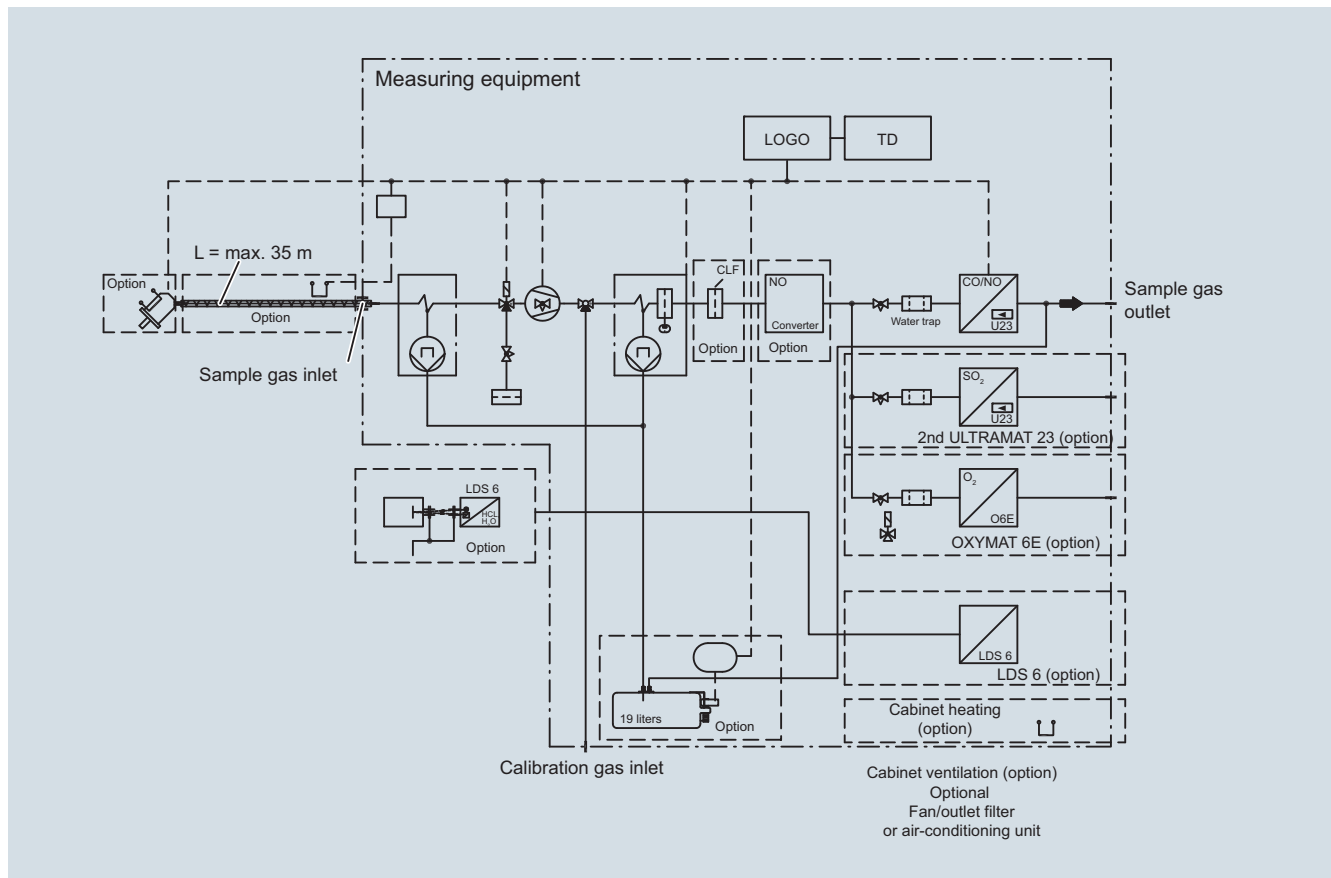

Set CEM 1, gas flow chart, figure contains options

Function

A sample is extracted via the heated sample gas probe. The dust concentration may be up to 2 g/m³, the sample gas temperature up to 600 °C. The gas is transported to the analysis cabinet via a heated sample gas line. The heating prevents condensate. The gas cooler cools and dries the sample in the analysis cabinet. Condensate is drained. The level in the condensate trap is monitored. For safety purposes, a coalescence filter can be provided in addition to the fine filter and moisture filter which are always present. The sample gas is analyzed by analyzers such as the ULTRAMAT 23, OXYMAT 6 and LDS 6. The ULTRAMAT 23 operates on the basis of molecular-specific absorption of infra-red radiation or with an electrochemical oxygen measuring cell. The OXYMAT 6 is an analyzer for paramagnetic oxygen measurements. The in-situ LDS 6 laser diode spectrometer operates according to the molecular-specific absorption of near-IR radiation. The delivery may also include an NO₂/NO converter which permits measurement of total nitrogen oxides. In order to qualify the set for low or high temperature ranges (-5, +45 °C), it is possible to use a cabinet heater or air-conditioning unit. Power supply versions are available for 115, 230 or 400 V AC. Electronic consumers can be provided with single-pole or double-pole fusing. The components of the sample preparation system and the analyzers are connected to LOGO modules via a binary signal, and transmit maintenance requirements. The analog signals can be processed either singly or twice. Electrical isolation is additionally possible for the double processing.

Technical specifications

Climatic conditions

Ambient temperature	0 ... 35 °C
• With heater in sheet-steel cabinet	Min. -5 °C
• With heating in GRP cabinet	Min. -15 °C
• With air-conditioning	Max. 52 °C
Relative humidity	70 %, non-condensing
Corrosive atmosphere	No

Gas inlet conditions

Max. sample gas pressure at inlet to sample preparation system	500 hPa (mbar)
Max. moisture content in sample gas	17 vol-% ¹⁾
Max. water dew point	60 ?
Min. sample gas pressure at inlet to sample preparation system	180 °C
Dust content at inlet to sample preparation system	Dust-free
Sampling probe	Sampling tube 20 x 1.5, 1 000 mm long, stainless steel, flange: DN 65, PN 6
Max. sample gas pressure at sampling probe	500 hPa (mbar)
Max. sample gas temperature at sampling probe	600 °C
Max. dust content at sampling probe	2 g/Nm ³
Sample gas must not be flammable or explosive.	

Power supply

Supply 1	115 V AC (-15 %, +10 %)
Supply 2	230 V AC (-15 %, +10 %)
Supply 3	400 V AC (-15 %, +10 %)

Connections

Hose material	Teflon
Cables	Not armored, not halogen-free
Electrical design	According to IEC
Cable ID	Individual core labeling as option
Fusing of electronic consumers	1-pole; 2-pole as option
Duplication of analog signals	<ul style="list-style-type: none"> • Not electrically isolated as option • Electrically isolated as option

Installation

Site	Indoor installation
• In sheet-steel cabinet/frame	Outdoor installation
• In GRP cabinet	
Ex zone	Non-Ex area

System design

Type	Mounting frame or cabinet
Cabinet degree of protection	IP54
Automatic calibration	Yes, with ULTRAMAT 23

Detailed information on the analyzers

- You can find detailed information on the analyzers:
- In the "Continuous Gas Analyzers, extractive" chapter
 - ULTRAMAT 23
 - OXYMAT 6
 - In the "Continuous Gas Analyzers, in-situ" Chapter
 - LDS 6

Dimensions (without plinth)

Depth of sheet-steel frame	
• 800 mm (without plinth)	2 000 x 800 x 800 mm (H x W x D)
• 600 mm (without plinth)	2 000 x 800 x 600 mm (H x W x D)
GRP cabinet (with plinth)	2 080 x 900 x 600 mm (H x W x D)

It is necessary to provide a 500 mm gap to the right or left for the tube or cable inlet.

Use of the LDS 6 requires a cabinet with a depth of 800 mm.

¹⁾ Higher performance sample gas coolers can be offered upon request (not TÜV suitability-tested). A higher performance cooler is generally required for high sulfide content in fuels (e.g. heavy oil).

Analytical Application Sets

Continuous emission monitoring

Set CEM 1

Selection and ordering data	Article No.	
Set CEM 1 – Continuous Emission Monitoring	7MB1953-	Cannot be combined
↗ Click on the Article No. for the online configuration in the PIA Life Cycle Portal.		
<u>Rack</u>		
Rack 1: 2 000 x 800 x 800 mm (H x W x D), with sample preparation device, with hinged frame 40 HU, hose/cable inlet on left side, with lighting, prepared for 1 x ULTRAMAT 23, max. five 19" rack units possible	0	A03, A04, B02, B04
Rack 2: 2 000 x 800 x 800 mm (H x W x D), with sample preparation device, with hinged frame 40 HU, hose/cable inlet on right side, with lighting, prepared for 1 x ULTRAMAT 23, max. five 19" rack units possible	1	A03, A04, B02, B04
Rack 3: 2 000 x 800 x 600 mm (H x W x D), with sample preparation device, with hinged frame 40 HU, hose/cable inlet on left side, with lighting, prepared for 1 x ULTRAMAT 23, max. five 19" rack units possible, not suitable for LDS 6	2	A01, A02, B01, B03, E01 ... E06, F01 ... F06, G01 ... G04
Rack 4: 2 000 x 800 x 600 mm (H x W x D), with sample preparation device, with hinged frame 40 HU, hose/cable inlet on right side, with lighting, prepared for 1 x ULTRAMAT 23, max. five 19" rack units possible, not suitable for LDS 6	3	A01, A02, B01, B03, E01 ... E06, F01 ... F06, G01 ... G04
Rack 5: 2 060 x 900 x 600 mm (H x W x D), GRP, base 80 mm, with sample preparation device, with hinged frame 40 HU, hose/cable inlet on left side, with lighting, prepared for 1 x ULTRAMAT 23, with side panels, incl. door with window, max. five 19" rack units possible, not suitable for LDS 6	4	A01 ... A04, B01 ... B04, E01 ... E06, F01 ... F06, G01 ... G04
Rack 6: 2 060 x 900 x 600 mm (H x W x D), GRP, base 80 mm, with sample preparation device, with hinged frame 40 HU, hose/cable inlet on right side, with lighting, prepared for 1 x ULTRAMAT 23, with side panels, incl. door with window, max. five 19" rack units possible, not suitable for LDS 6	5	A01 ... A04, B01 ... B04, E01 ... E06, F01 ... F06, G01 ... G04
<u>Sampling probe</u>		
Without	A	
Standard sampling probe	B	
<u>Ventilation/cooling</u>		
Without	A	
Fan with outlet filter	B	
Cabinet air-conditioning unit	C	
Cabinet air-conditioning unit for GRP rack	D	
<u>Heating</u>		
Without	0	
Cabinet heating	1	
<u>Fuse protection</u>		
1-pole	0	
2-pole	1	
<u>Removal of condensation</u>		
Without	0	
19 l container with level monitoring	1	
<u>NO₂/NO converter</u>		
Without	A	
NO ₂ /NO converter	B	
<u>Power supply</u>		
115 V AC, -15 %, +10 %, 50 or 60 Hz	A	
230 V AC, -15 %, +10 %, 50 or 60 Hz	B	
400 V AC, -15 %, +10 %, 50 or 60 Hz (3 phases, neutral, ground provided by customer)	C	
<u>Connection set for heated line</u>		
Without controller	0	
Standard controller (max. 35 m heated line can be connected)	1	
Note: The heated sample gas line must be ordered separately using Catalog PA 11.		

<i>Additional versions</i>	Order code
Add "-Z" to Article No. and specify Order code	
Bases	
Base for rack 1, 2, height 100 mm	A01
Base for rack 1, 2, height 200 mm	A02
Base for rack 3, 4, height 100 mm	A03
Base for rack 3, 4, height 200 mm	A04
Rack accessories	
Outer panel painted, for rack 1 and 2, viewing door	B01
Outer panel painted, for rack 3 and 4, viewing door	B02
Outer panel painted, for rack 1 and 2, sheet steel door	B03
Outer panel painted, for rack 3 and 4, sheet steel door	B04
ULTRAMAT 23, OXYMAT 6 extractive analyzers	
ULTRAMAT 23: CO, NO	C01
ULTRAMAT 23: CO, NO, SO ₂	C02
ULTRAMAT 23: CO, NO, CO ₂	C03
ULTRAMAT 23: CO ₂	C04
ULTRAMAT 23: Electrochemical O ₂ sensor for ULTRAMAT 23 expansion	C05
OXYMAT 6: OXYMAT paramagnetic O ₂ analyzer	C06
Preparation for free choice ULTRAMAT 23 analyzer	C07
Additional sample preparation components	
Coalescence filter	D02
LDS 6 in-situ analyzers	
HCl including sensor pair	E01
HCl/H ₂ O including sensor pair	E02
HF including sensor pair, not suitability-tested	E03
HF/H ₂ O including sensor pair, not suitability-tested	E04
NH ₃ including sensor pair	E05
NH ₃ /H ₂ O including sensor pair	E06
LDS 6 hybrid cable per LDS 6	
5 m	F01
10 m	F02
25 m	F03
40 m	F04
50 m	F05
Customer-specific > 50 m	F06
LDS 6 connecting cable per LDS 6	
5 m	G01
10 m	G02
25 m	G03
Customer-specific > 25 m	G04
Electrical preparation	
Preparation for dust measurement	J01
Preparation for flow measurement	J02
Preparation for pressure measurement	J03
Preparation for temperature measurement	J04
Preparation for emission data memory – DIN rail module (on request)	J05
Preparation for emission data memory – 19" rack unit (on request)	J06
Additional LOGO	
LOGO for a third and fourth 19" rack unit	K01

Analytical Application Sets

Continuous emission monitoring

Set CEM 1

Additional versions

Core end labeling

Single-core labeling Siemens standard

Analog signal processing

Double, galvanically connected, 1 x per analog signal

Double, galvanically isolated, 1 x per analog signal

Documentation

German

English

French (on request)

Order code

L01

M01

M02

N01

N02

N03

Dimensional drawings

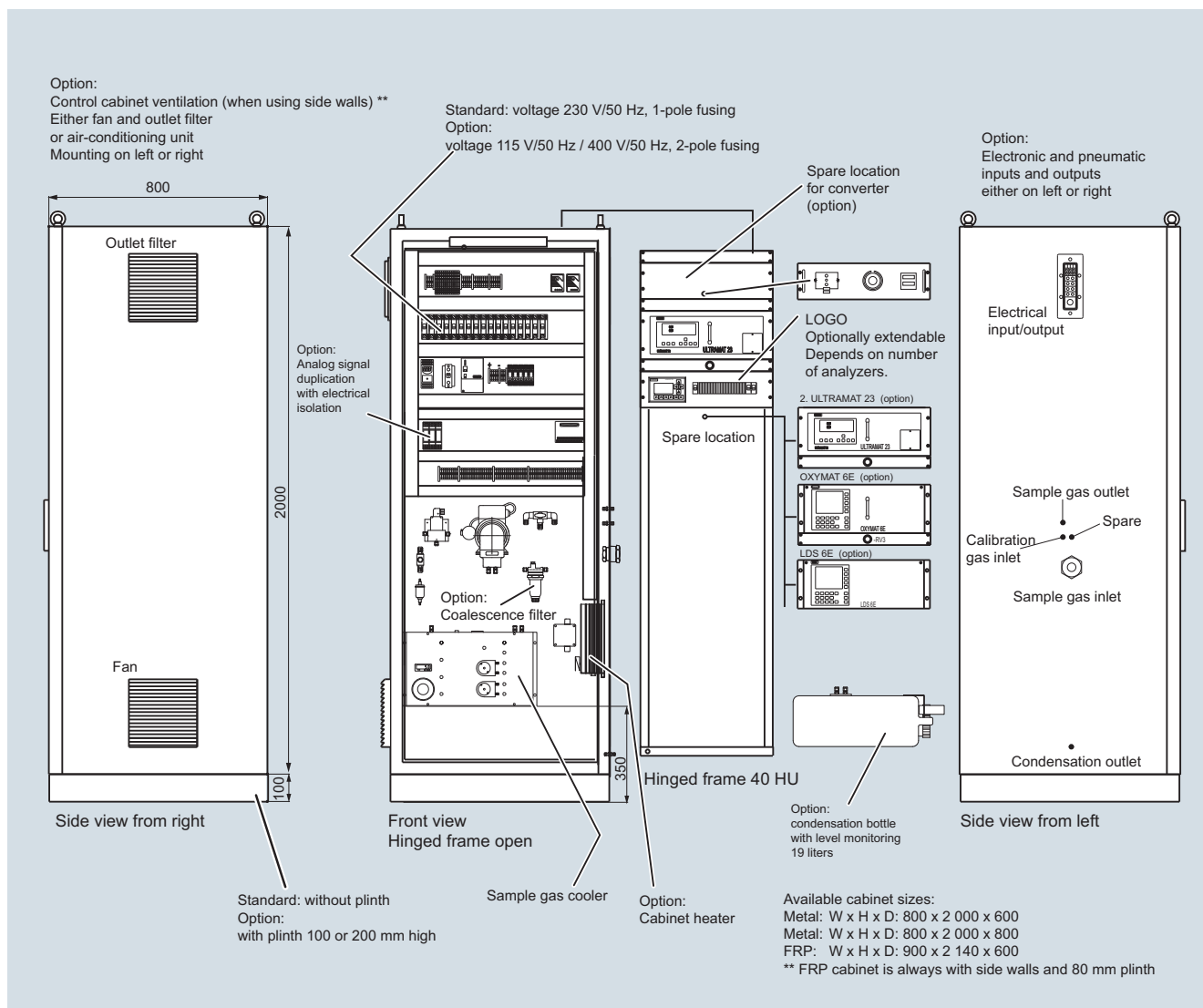

Design of the Set CEM 1, figure contains options, dimensions in mm